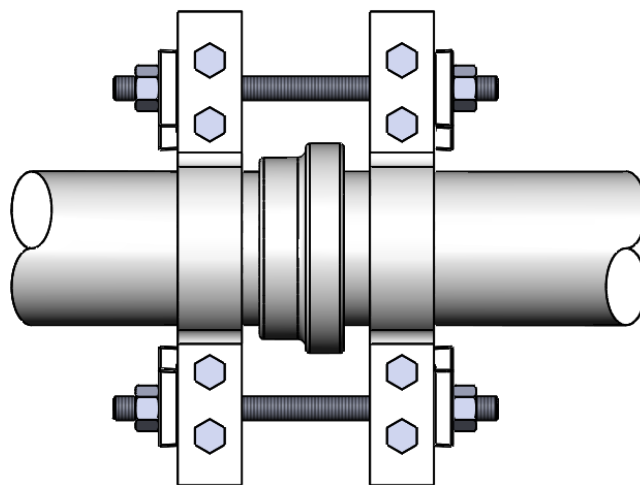
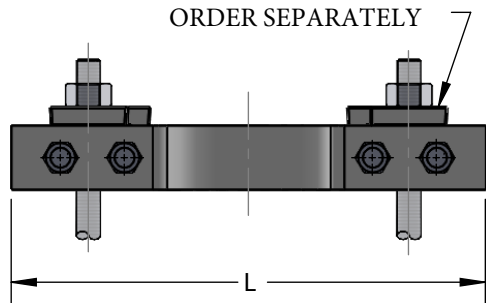

FIG. 599 WASHER
ORDER SEPARATELY



TYPICAL
INSTALLATION

Materials/Finishes:	Plain Carbon Steel (595B)	Electro-Galvanized (595G)
	Hot-Dip Galvanized (595HDG)	
Variants:	N/A	
Service:	Designed to be used to clamp mechanical joint or socket joint piping and fittings together to prevent separation or distortion of pipe lines under excessive water pressure.	
Approvals:	Complies with the requirements of the National Fire Protection Association standard NFPA 24 for outside protection.	
Ordering:	Specify figure number, finish and size.	
Notes:	N/A	



PIPE SIZE	PIPE OD	BOLT	A	INNER DIA.	L	WGT EACH (lbs)
3	3.960	5/8	3/4	3.9	13	8.6
4	4.800	5/8	3/4	4.8	14-5/8	9.38
6	6.900	5/8	3/4	6.9	16-7/8	11.50
8	9.050	5/8	3/4	9.05	19-1/8	20.54
10	11.100	3/4	1	11.1	21-3/8	23.15
12	13.200	7/8	1	13.2	25-1/8	35.85
14	15.300	7/8	1-1/4	15.3	28-1/4	46.78
16	17.400	1	1-1/4	17.4	31-3/8	70.53
18	19.500	1-1/4	1-1/4	19.4	35-1/8	84.65
20	21.600	1-1/4	1-3/8	21.6	37-3/4	98.65
24	25.800	1-1/2	1-1/2	25.8	44-1/4	135.50

PROJECT INFORMATION	APPROVAL STAMP
Project:	Notes:
Address:	
Contractor:	
Engineer:	
Date:	
Approved Approved as Noted Not Approved	