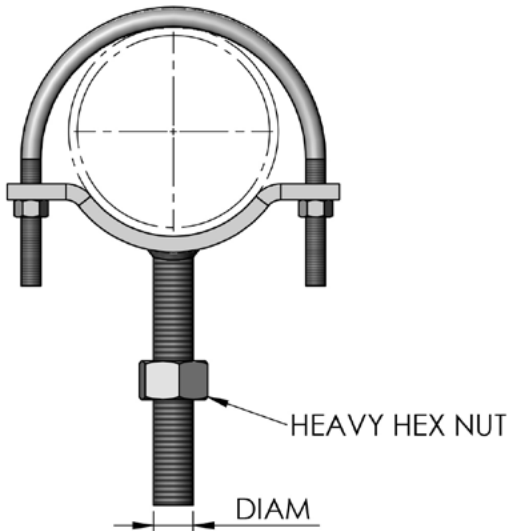

FIG. 422UDIP adjustable pipe support w/ u-bolt for ductile iron pipe



Materials/Finishes:	Plain Carbon Steel (422UDIPB)	Electro-Galvanized (422UDIPG)
	Hot-Dip Galvanized (422UDIPHGD)	T-304 Stainless Steel (422UDIPSS)
	T-316 Stainless Steel (422UDIPSX)	
Variants:	N/A	
Service:	Designed to be used in conjunction with a standard pipe and flange at the base to support piping where an overhead supporting member is not available. The stem is threaded the full length with a nut to allow vertical adjustment to accommodate the pitch in the pipe line.	
Ordering:	Specify figure number, finish and pipe size	
Notes:	Base stand can be ordered separately (requires accurate center line of pipe to floor dimension). Due to the unknown variables within a field installation, Empire does not publish a maximum recommended load for a complete pipe support stanchion or any of its individual components. The customer /end-user is solely responsible for understanding the full capability of the piping system design.	

DIP SIZE	DIAMETER X LENGTH OF STEM	WGT EACH (lbs)
3	7/8 x 8	3.3
4	1 x 8	4.5
6	1-1/4 x 8	8.5
8	1-1/4 x 8	9.6
10	1-1/2 x 8	15.6
12	1-1/2 x 8	19.3

PROJECT INFORMATION	APPROVAL STAMP
Project:	Notes:
Address:	
Contractor:	
Engineer:	
Date:	
Approved Approved as Noted Not Approved	