

### ±5" Axial Movement, ±1/16" Lateral Movement

**SERVICE:** To support pipe while providing large axial movement and lateral guidance. Pad to be welded to structure and body welded to pipe. Slide bearing provides low coefficient of friction between body and pad to reduce stress on the pipe and supporting structure.

**MATERIAL:** Carbon Steel meeting ASTM A36  
Stainless Steel meeting ASTM A240 Type 304 and 316  
Slide Bearing: PTFE-on-PTFE, 3/32" thick glass filled PTFE bonded to 10 ga. back-up plate, 2000 psi compressive strength at 70°F (Note 2)

**FINISH:** Black or Hot-Dip Galvanized meeting ASTM A123

**MAX TEMP:** At Pipe Wall: 650°F for Black, 350°F for Hot-Dip Galvanized.  
At PTFE Bearing 300°F (Note 2 & 3)

**STANDARDS:** MSS SP-58 Type 35, FS A-A-1192A Type 35

**ORDERING:** Specify figure number, pipe size, and finish

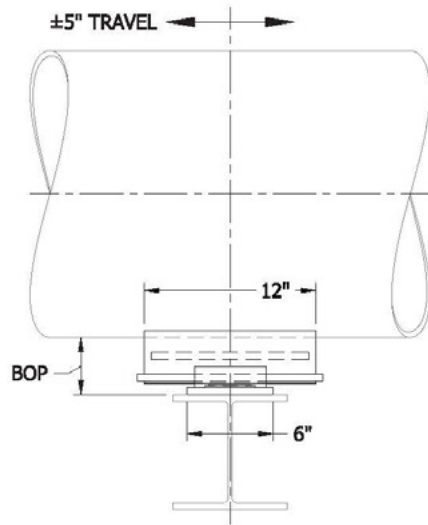
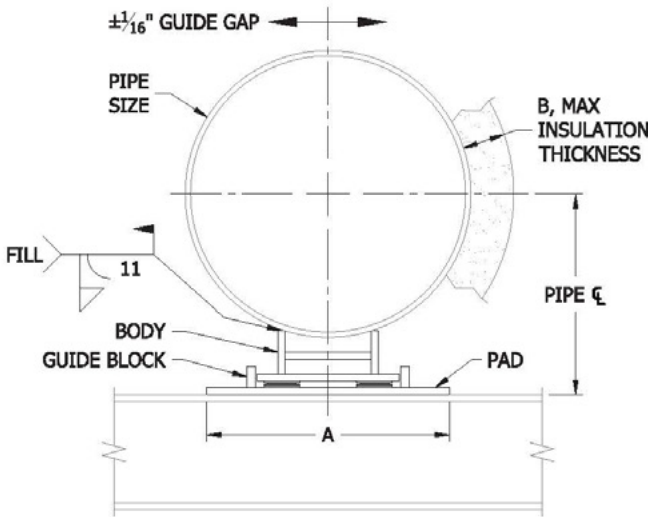
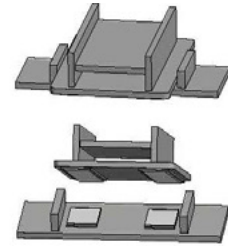

PIPE SIZE	PIPE cL	BOP	A	B	WEIGHT EACH, LBS	VERTICAL DOWN LOAD	LATERAL LOAD
6	8	4 1/8	10	3 1/2	26	12000	3000
8	9	4 1/8	10	3 1/2	26	12000	3000
10	9 7/8	4 1/2	12 1/2	3	37	16000	4000
12	11	4 5/8	12 1/2	3	37	16000	4000
14	11 1/8	4 1/8	14 1/2	3	54	16000	4000
16	12 5/8	4 3/8	14 1/2	3	54	16000	4000
18	12 7/8	3 7/8	17	3	58	16000	4000
20	14	4	17	3	58	16000	4000
24	15 7/8	3 7/8	19	3	68	24000	6000
30	19 7/8	4 7/8	21	4	80	24000	6000
36	23 1/4	5 1/4	23	4	111	24000	6000

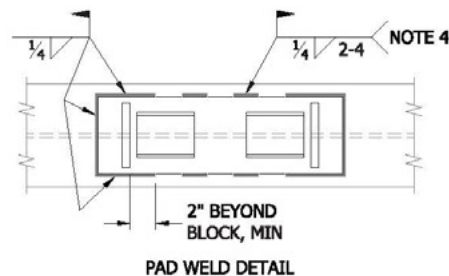

**NOTES:**

- Special fabricated configurations available upon request for options: pad bolted to structure, body clamped to pipe, specified bottom of pipe (BOP), custom axial / lateral travel, insulation banding slots, heat loss notches, etc. Provide performance criteria and dimensions.
- Allowable vertical load at 70°F bearing temperature. See Supplemental Data for load reduction factors at higher bearing temperatures.
- For bearing temperatures 300°F to 500°F, specify High Temperature adhesive (-HT).
- Pad may be seal welded to structure with all-around weld.
- Body interchangeable with 955S, 955L, and 955U pads for same pipe size and "A" dimension.
- See Fig 955 Supplemental Data for other structural attachment details, slide bearing information, etc.

PROJECT INFORMATION			APPROVAL STAMP
Project:			Notes:
Address:			
Contractor:			
Engineer:			
Date:			
Approved	Approved as Noted	Not Approved	